

BG2 INSTRUCTION MANUAL

Standard Model

FT-BG2-*

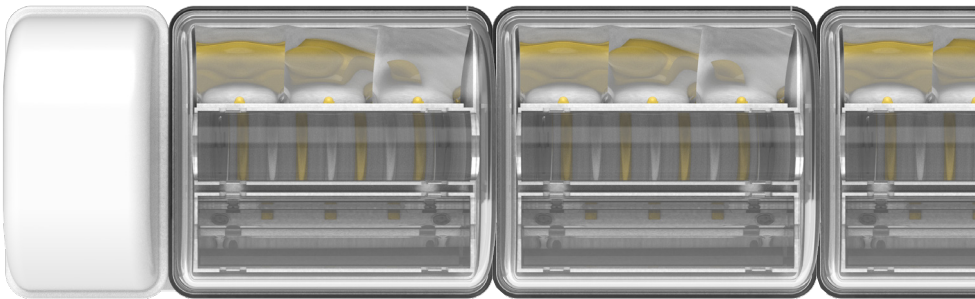

HiViz LED Lighting
HiViz Lighting, Inc
Phone: 703-662-3458
Email: firetech@hizizleds.com
PO Box 565, Naples, NC 28760



TABLE OF CONTENTS

Safety Regulations & Warranty3

What's Included4

General Description.....5

Technical Specifications6

Extruded Mounting Brackets7

Installation Instructions8-9

Wiring Information10-11

Weather Sealing Outer Plug.....12

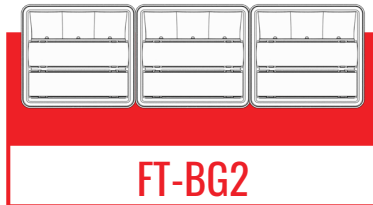

SAFETY NOTICE & WARRANTY

**WARNING: INSTALLATION MUST BE CONDUCTED BY A QUALIFIED TECHNICIAN.
IMPROPER INSTALLATION CAN RESULT IN INJURY OR DEATH.**

- Installation must be conducted by a qualified automotive electrician or emergency vehicle technician in accordance with the applicable NFPA standard(s) and procedures (Including but not limited to NFPA 1901, 1906, 1911, 414, 1900)
- Improperly installed, aimed, or operated lights can create significant hazard to motorists which can result in collision. Ensure light fixtures are installed and operated such that their beam does not shine into oncoming traffic
- All circuits must be fused at 125% of the rated power consumption of the loads on the circuit
- A voltage drop greater than 10% in the power feed to a fixture could be an indicator of an under-sized conductor. Use of improperly sized conductors will, at a minimum, result in poor performance, and at a maximum could result in fire
- Verify input voltage is within fixture range before installation. Voltage range information can be found in this manual or printed on the fixture body
- The use of personal protective equipment (safety glasses and gloves) is highly recommended
- Allow proper cooling time before handling the fixture if it has been installed & powered to prevent burns
- Any modifications to the fixture will void warranty and are not authorized by the manufacturer
- Always inspect the fixture for any damage prior to installing and DO NOT install if any damage is present



Warranty Information: Full policy available Online at www.hivizleds.com/warranty

- Proof of purchase may be required to validate warranty. All FireTech products are warranted for the useful service life of the vehicle for which they were first installed
- Improper installation, accident, physical damage, neglect, and normal wear and tear are not covered under warranty
- Lights operated in environments over 150° Fahrenheit are not covered under warranty
- All advance-exchange warranty claims must be validated with HiViz Technical Support prior to issuance of a shipping label. Failure to return defective product will result in an invoice for the full replacement value of the product
- HiViz Lighting will repair or replace defective product at its discretion. Replacement product will be in similar or better cosmetic condition than the defective part
- Warranties should be handled through the dealer/reseller the product was purchased from; customer is responsible for delivery
- If product is found to have damage not covered under warranty, customer will be responsible for return shipping charges and/or cost of repair
- Non-warranted items can be repaired at the customer's expense of parts and labor, at the discretion of HiViz LED Lighting, who will provide an estimated repair cost before proceeding with the repair



WHAT'S INCLUDED

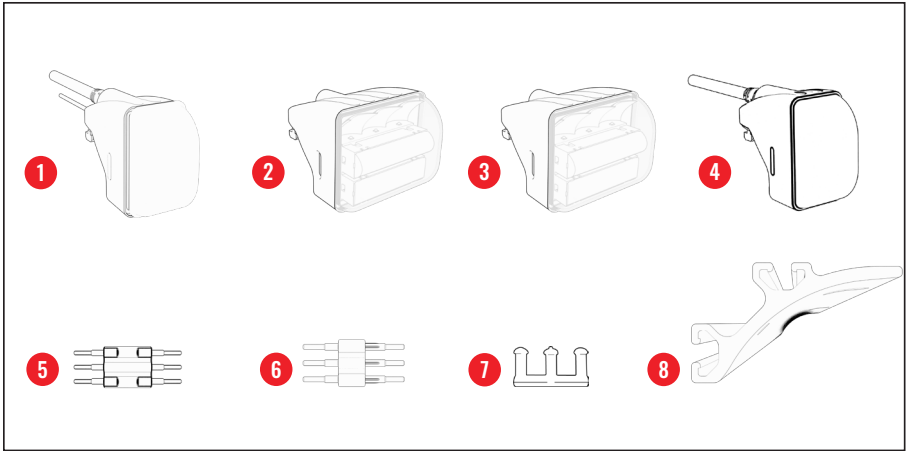

PIECES INCLUDED

- | | |
|--|--|
| 1 2in Power + Control Module (4x 12v triggers)
P/N FT-BG2-CON-MC4-*(housing color) | 5 Module to Module Pins
P/N ACNBG2MOD6P |
| 2 4in Light Module(s) (non-marker)
P/N FT-BG2-MOD-SAA-*(housing color) | 6 Controller to Module Pins
P/N ACNBG2CON6P |
| 3 4in Marker Light Module(s)
P/N FT-BG2-MOD-SAA-ML-*(housing color) | 7 Weather Sealing Outer Plug
P/N ACPBG2CONWH |
| 4 2in Power-Only Module
P/N FT-BG2-CON-CO-*(housing color) | 8 Extruded Mounting Bracket
(See page 7 for a breakdown) |

NOTE:

This product does not ship with mounting hardware. HiViz recommends installer choose appropriate hardware based on vehicle application.

TOOLS REQUIRED

- 4mm Allen Wrench
- Basic Automotive Wiring Supplies
- Plastic Body Trim Tool

WARNING:

Tighten screws by hand/screwdriver.
Pneumatic devices can cause damage
and void warranty.



GENERAL DESCRIPTION

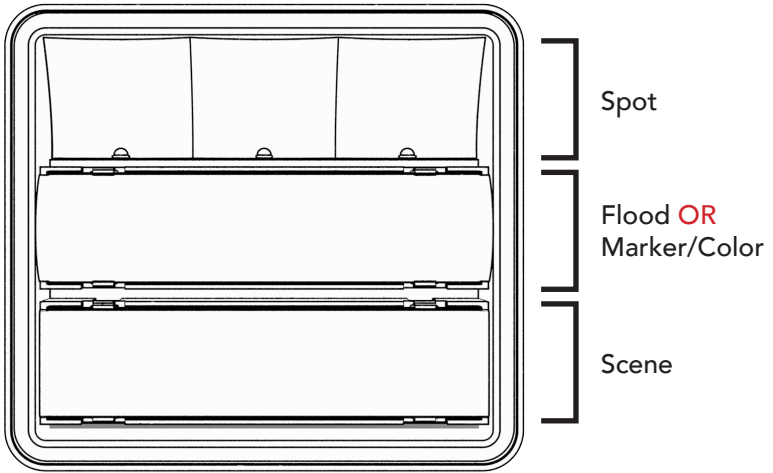

4in Light Module shown above

- The BG2 is comprised of up to **nineteen (19)** “4in Light Modules”.
- The light modules are coupled with endcap controller(s) and mounted along an extrusion to make a single fixture.
- Each light module has 4 LED circuits, divided across 3 separate optical groups.
- The tubular acrylic “Flood” optic sits atop 2 sets of independent LED circuits (“flood” or “marker/color”), unless marker is disabled.
- “Marker” Modules do not respond to calls for “flood” light.
- “Non-Marker” Modules do not respond to calls for “marker” light.

CIRCUITRY AND THERMAL OPTIMIZATION

- Each “4in Light Module” is designed to dissipate up to a total of 32 watts of heat passively into the rail and atmosphere.
- Each white-light circuit has three 5-watt LEDs
- The color circuit uses three 3-watt LEDs, and is only on marker modules.
- The module firmware is designed to ensure the thermal load never exceeds the maximum thermal capability of the housing and uses a logic table to maximize light output per circuit in any given operational mode. In practice, this allows the operator to choose a beam shape (control where the Lux go), without having to choose a light output volume (choosing fewer Lumens).



TECHNICAL SPECIFICATIONS

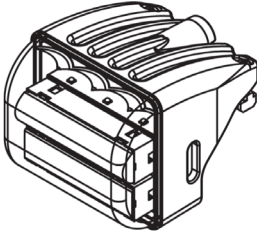

BG2 | 4" MODULE

VOLTAGE RANGE	9-32V DC
MAX POWER CONSUMPTION @ 13.8V DC	32 WATTS
RAW LUMENS PER MODULE	3,400
TRIGGER CURRENT DRAW	25mA
OPERATING TEMP. RANGE	-40°C-60°C
INGRESS PROTECTION RATING	IP67 AND IP69K
DIMENSIONS	3.554" X 3.937" X 4.606"

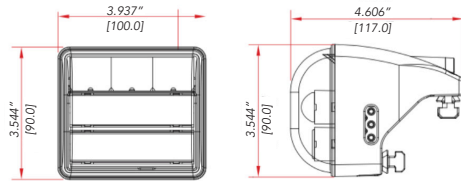

BG2 HIERARCHY

Module: A module is the smallest building block of the BG2S system. These modules are assigned a unique identifier during configuration at the factory.



Fixture: A fixture is a single complete lighting assembly it consists of light modules control modules and an extruded mounting track.



System: A system is a grouping of BG2 Smart fixtures controlled by a single central brain. Systems allow for multiple fixtures to act in a coordinated fashion and are programmed using a PC configuration utility.

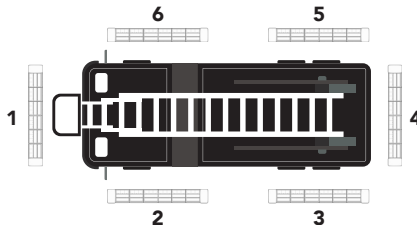

EXTRUDED MOUNTING BRACKETS

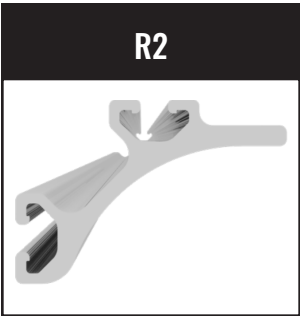

R2
2" Radius, Straight Extrusion
P/N FT-BG2-EXT-R2-*(length)-*(color)



R2C
2" Radius, Curved Extrusion
P/N FT-BG2-EXT-R2C-*(length)-*(color)



R275C
2.75" Radius, Curved Extrusion
P/N FT-BG2-EXT-R275C-*(length)-*(color)

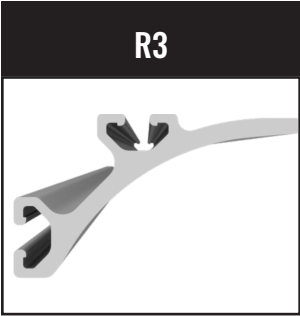

R3
3" Radius, Straight Extrusion
P/N FT-BG2-EXT-R3-*(length)-*(color)

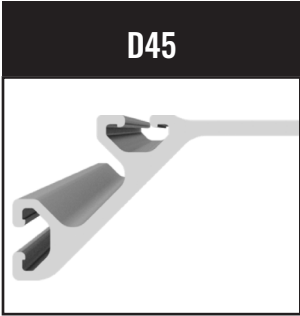

D45
45° Straight Extrusion
P/N FT-BG2-EXT-D45-*(length)-*(color)

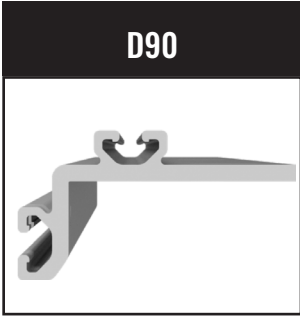

D90
90° Straight Extrusion
P/N FT-BG2-EXT-D90-*(length)-*(color)

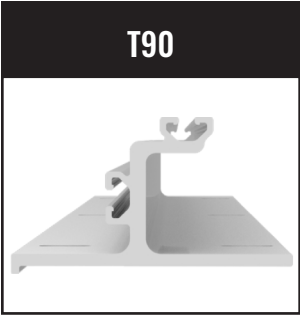

T90
"Top Mount" 90° Straight Extrusion
P/N FT-BG2-EXT-T90-*(length)-*(color)

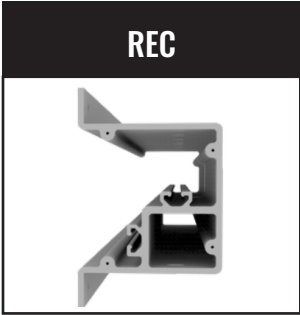

REC
Recessed Extrusion
P/N FT-BG2-EXT-REC-*(length)-*(color)



INSTALLATION INSTRUCTIONS

Care should be taken to ensure the correct part number is chosen for the intended application. Please see the downloads section of our BG2 page to make sure you have the correct configuration:

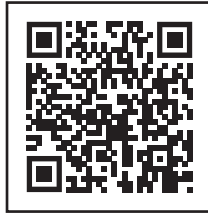

Mounting of the Clearance Marker lights should be as wide as practicable on the leading edge of the apparatus cab, with spacing following the guidelines set forth in FMVSS108, and each Gen 2 FireTech Brow Light is designed to be carefully paired with an apparatus cab has. **Please contact HiViz LED Lighting if you are unsure** of the correct placement or configuration.

During install, special care should be taken to ensure that extruded mounting bracket is secured to the vehicle such that the BG2 light modules are **mounted perfectly parallel** to the ground. This ensures the BG2 light modules deliver beam patterns as designed, and not too high or too low!

Any time the "marker" function is called by the "2in Power + Control Module", the message broadcast to the LIN bus is only acted on by modules listening for "marker" function. The light module firmware disables the white illumination circuit for the "flood" function from any marker module. This firmware lock-out prevents optically combined operation of a marker light with any other function, as required by SAE J2042.



Mounted with beam too high.



Mounted with beam too low.



Mounted parallel to ground.



INSTALLATION INSTRUCTIONS

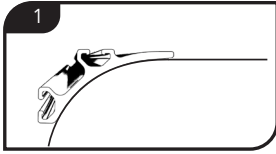

1
Make sure your extrusion is the proper model by holding it to the radius/profile of the cab and ensuring that there is a flush fit, without any gaps between the two surfaces.

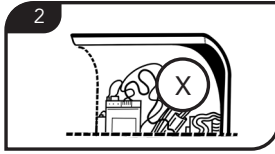

2
Go inside the apparatus and ensure there are not any obstructions (AC parts, wires, etc).

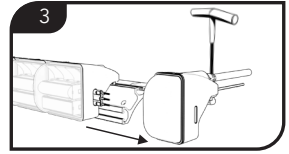

3
To reveal the mounting holes, you will need to remove the outermost left and right modules. Using a 4MM allen wrench, loosen the socket cap screws at the back of the module (do not remove bolt) and slide module straight out.

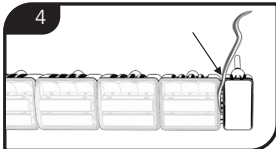

4
If the module does not slide off easily, double check the T-Nuts are loosened enough and use a plastic body trim tool to separate the modules.

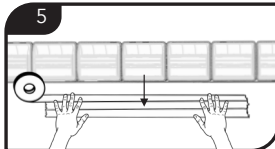

5
Apply a tape layer to where the BG2 is to be mounted on the apparatus. Mark face mounting holes, bottom first then top ones.

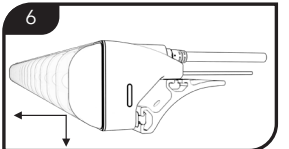

6
Position the light so that the beam pattern is parallel to the road plane and the lens is perpendicular to it.

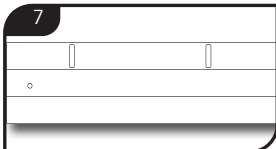

7
Use a center punch to prevent drill bit from wandering and mark the location where you will drill your holes. Drill mounting holes as desired (or drill & tap). Remove masking tape and install mounting hardware (not included).

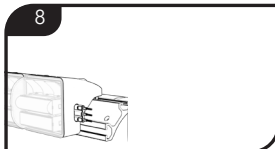

8
Seal mounting hardware/holes using RTV silicone.

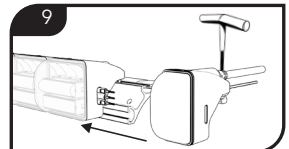

9
Re-install module on track, ensuring pins seat fully and housing is tight pressed up against neighboring module. Re-tension T-Nuts to secure permanently. Do not over-tighten T-Nuts as damage to extrusion can occur.

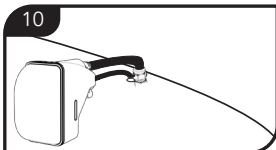

10
Mark the hole for the power cable, drill the hole, drop the wire in, and make your connections on the inside. On the side with two wires (the data and control wire is slimmer, the power cable is larger), use two separate cable glands to prevent leaking.

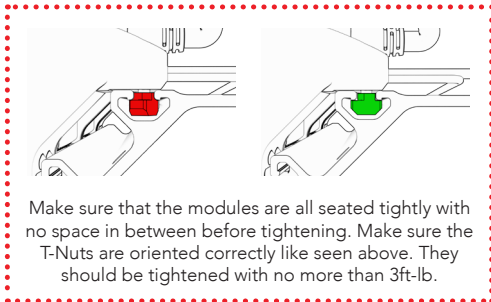

Make sure that the modules are all seated tightly with no space in between before tightening. Make sure the T-Nuts are oriented correctly like seen above. They should be tightened with no more than 3ft-lb.



WIRING INFORMATION

The fuse chart (see chart on right) should be used for the FT-BG2 fixture.

This chart assumes nominal voltage of 13.8 V DC and an overcurrent rating of 20% of the expected maximum load.

If two power modules are present (“2in Power + Control Module” and “2in Power Only Module”), both circuits must be attached to the same fuse. If the power modules are split on independent fuses, and one fuse fails, the interconnect pins will experience a higher-than-acceptable current which will cause voltage drop and irreparable damage to the fixture. Wire gauge calculations can be made using “Max Amp Draw” data from the middle column.

Voltage drop across the power conductors feeding the fixture (under load) should never exceed 10% of the chassis’ nominal voltage.

The table below table illustrates how the firmware limits the maximum wattage at the module level.

Number of Modules	Max Amp Draw (A)	Fuse Value* (A)
1	2.5	5
2	5	7.5
3	7.5	10
4	10	15
5	12.4	15
6	14.9	20
7	17.4	25
8	19.9	25
9	22.4	30
10	24.8	30
11	27.3	35
12	29.8	40
13	32.3	32.3
14	34.8	45
15	37.2	45
16	39.7	50
17	42.2	55
18	44.7	55
19	47.2	60

* Assumes 12.8v DC

Single “4in Light Module” Power Consumption Data		
Circuit Name	Wattage	Amperage*
Spot (individual)	12	0.94
Flood (individual)	12	0.94
Scene (individual)	12	0.94
Color (individual)	8	0.63
Spot + Flood + Scene (combined)	24	1.9
Spot + Flood + Color (combined)	32	2.5
Spot + Scene + Color (combined)	32	2.5
Flood + Scene + Color (combined)	32	2.5
Spot + Flood + Scene + Color (combined)	32	2.5

Dim action when spot/flood/scene are switched on simultaneously (36W to 24W @ 1 Module)

* Assumes 12.8V DC



WIRING INFORMATION

- The FT-BG2 should be wired as shown below.
- The main power wires going to the FT-BG2 “2in Power Only Module” and “2in Power + Control Module” must be attached to switched battery power and protected by an appropriately sized fuse.
- The trigger wires should be connected to the desired switch or node per customer specifications, and must be 12V VCC.
- Trigger wires should be fused at 0.5-2 A. Installation must be conducted by a qualified EVT or other installer competent in automotive electronic installation.
- Installation must always follow national best practices outlined in NFPA 1901 (Ch. 13).

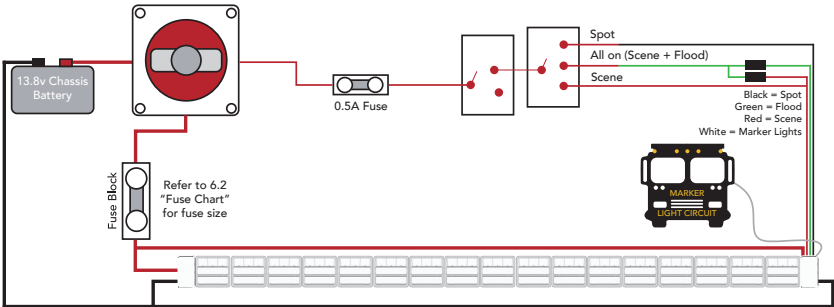
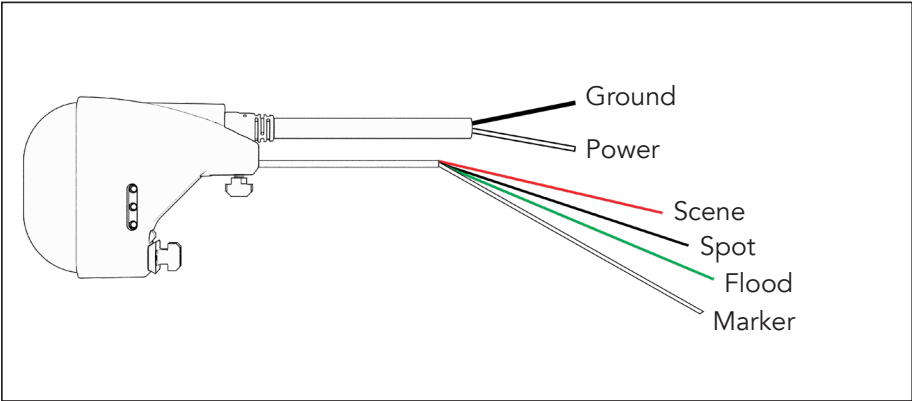

WEATHER SEALING OUTER PLUG

Weather Sealing Outer Plugs: Because the BG2 modules (the "2in Power + Control Module", "2in Power Only Module", and "4in Light Module") are all interconnected using the 3 pin connectors, the outer 2 modules will always have a single side that does not have a 3 pin connector. To ensure proper weather proofing of these outer modules, a **3 pin "plug" should be used on the outside side of the outer 2 modules.**

The weather sealing outer plug is shown above on the left, and shown installed on a "2in Power + Control Module" on the right. Installation on "2in Power Only Module" and "4in Light Module" is done in the same manner.

NOTE: Ensure this step is not skipped during installation, or the weather proofing may be compromised and cause water damage to the BG2 lighting system.

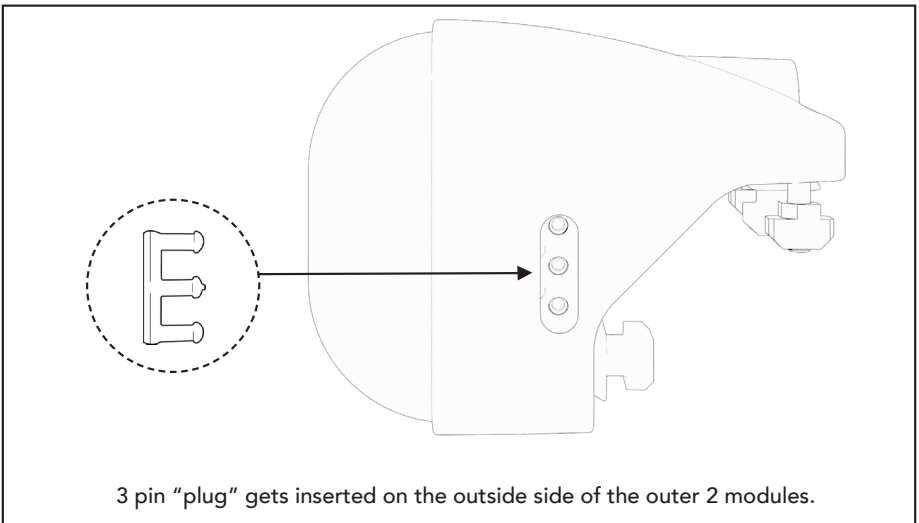

IMPORTANT: Use small screwdriver or similar tool to push in the weather sealing outer plug and ensure it is completely inserted. The weather sealing outer plug on the 2in module should be slightly recessed when fully inserted. The weather sealing outer plug on the 4in module should be completely recessed.

